

SOLID MECHANICS

DYNAMICS

TUTORIAL –NATURAL VIBRATIONS – ONE DEGREE OF FREEDOM

This work covers elements of the syllabus for the Engineering Council Exam D225 – Dynamics of Mechanical Systems, C105 Mechanical and Structural Engineering and the Edexcel HNC/D module Mechanical Science. Oscillations with two degrees of freedom are covered in other tutorials and these are vital for those sitting exam D225.

On completion of this tutorial you should be able to do the following.

- Explain the meaning of “degrees of freedom”.
- Define and explain Simple Harmonic Motion.
- Explain the meaning of free vibrations.
- Show how various systems vibrate with simple harmonic motion.
- Determine the natural frequency and periodic time for simple systems.
- Determine the displacement, velocity and acceleration of bodies vibrating with simple harmonic motion.
- Explain the use of energy to analyse vibrations (Rayleigh’s Method)
- Explain how to combine several natural frequencies (Dunkerley’s Method)

This tutorial covers the theory of natural vibrations and brings together other areas of studies in the process. To do the tutorial fully you must be familiar with the following concepts.

- Spring Force.
- Inertia.
- Moment of inertia.
- Moment of force.
- Law’s of motion.
- Basic calculus.
- The deflection of beams.
- The twisting of shafts.
- Strain energy.
- Buoyancy.

All these topics may be found in other tutorials.

Contents

1. Free Vibrations
 - 1.1 Degrees of Freedom
 - 1.2 Free Vibrations - Examples
 - 1.3 Simple Harmonic Motion.
 - 1.4 Angular Frequency, Frequency and Periodic Time.
 - 1.5 Equations of Simple harmonic Motion.
2. Analysis of Natural Vibrations.
3. Simple Pendulum.
4. Linear Elastic Vibrations.
 - 4.1 Mass-Spring System
 - 4.2 Transverse Vibrations (of beams)
 - 4.3 Energy Methods (Rayleigh)
 - 4.4 Transverse Vibrations due to the distributed mass.
 - 4.5 Combination of Distributed and Point Loads (Dunkerley)
5. Torsional Oscillations.
6. Oscillation of a Floating Body

1. FREE VIBRATIONS

1.1 DEGREES OF FREEDOM

The numbers of degrees of freedom that a body possesses are those necessary to completely define its position and orientation in space. This is useful in several fields of study such as robotics and vibrations.

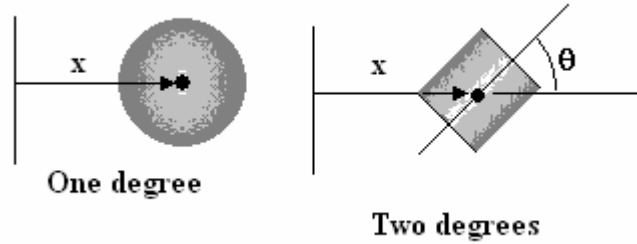

Figure 1

Consider a spherical object that can only be positioned somewhere on the x axis. This needs only one dimension, 'x' to define the position to the centre of gravity so it has one degree of freedom. If the object was a cylinder, we also need an angle 'θ' to define the orientation so it has two degrees of freedom.

Now consider a sphere that can be positioned in Cartesian coordinates anywhere on the z plane. This needs two coordinates 'x' and 'y' to define the position of the centre of gravity so it has two degrees of freedom. A cylinder, however, needs the angle 'θ' also to define its orientation in that plane so it has three degrees of freedom.

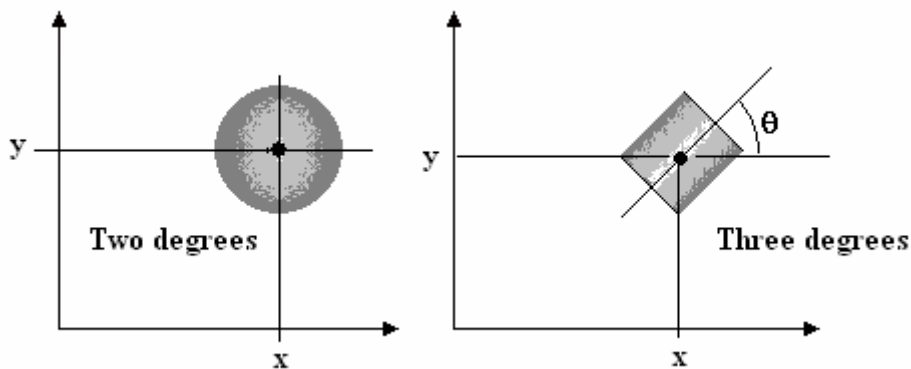

Figure 2

In order to completely specify the position and orientation of a cylinder in Cartesian space, we would need three coordinates x, y and z and three angles relative to each angle. This makes six degrees of freedom. In the study of free vibrations, we will be constrained to one degree of freedom.

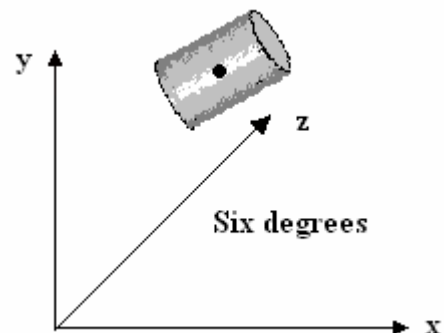

Figure 3

1.2 FREE VIBRATIONS- EXAMPLES

A free vibration is one that occurs naturally with no energy being added to the vibrating system. The vibration is started by some input of energy but the vibrations die away with time as the energy is dissipated. In each case, when the body is moved away from the rest position, there is a natural force that tries to return it to its rest position. Here are some examples of vibrations with one degree of freedom.

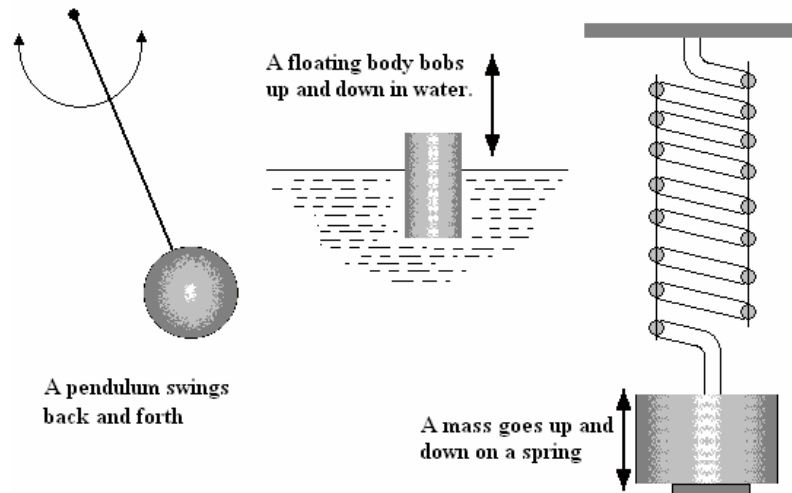

Figure 4

Note that the mass on the spring could be made to swing like a pendulum as well as bouncing up and down and this would be a vibration with two degrees of freedom.

The motion that all these examples perform is called SIMPLE HARMONIC MOTION (S.H.M.). This motion is characterised by the fact that when the displacement is plotted against time, the resulting graph is basically sinusoidal. Displacement can be linear (e.g. the distance moved by the mass on the spring) or angular (e.g. the angle moved by the simple pendulum). Although we are studying natural vibrations, it will help us understand S.H.M. if we study a forced vibration produced by a mechanism such as the Scotch Yoke.

1.3 SIMPLE HARMONIC MOTION

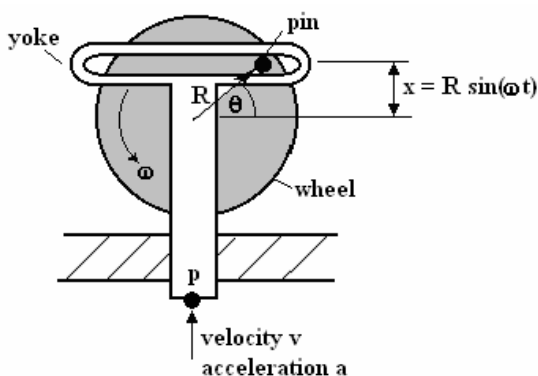

Figure 6

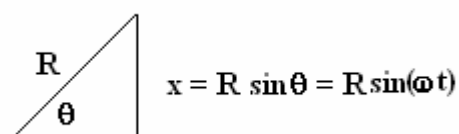

Figure 5

The wheel revolves at ω radians/sec and the pin forces the yoke to move up and down. The pin slides in the slot and Point P on the yoke oscillates up and down as it is constrained to move only in the vertical direction by the hole through which it slides. The motion of point P is simple harmonic motion. Point P moves up and down so at any moment it has a displacement x , velocity v and an acceleration a .

The pin is located at radius R from the centre of the wheel. The vertical displacement of the pin from the horizontal centre line at any time is x . This is also the displacement of point P . The yoke reaches a maximum displacement equal to R when the pin is at the top and $-R$ when the pin is at the bottom. This is the amplitude of the oscillation. If the wheel rotates at ω radian/sec then after time t seconds the angle rotated is $\theta = \omega t$ radians. From the right angle triangle we find $x = R \sin(\omega t)$ and the graph of $x - \theta$ is shown on figure 7a.

Velocity is the rate of change of distance with time and in calculus form $v = dx/dt$. If we differentiate x we get $v = dx/dt = \omega R \cos(\omega t)$. The plot is also shown on figure 7a.

The maximum velocity or amplitude is ωR and this occurs as the pin passes through the horizontal position and is plus on the way up and minus on the way down. This makes sense since the tangential velocity of a point moving in a circle is $v = \omega R$ and at the horizontal point they are the same thing.

Acceleration is the rate of change of velocity with time and in calculus form $a = dv/dt$. Differentiating v we get $a = dv/dt = -\omega^2 R \sin(\omega t)$. The plot is also shown on figure 7a. The amplitude is $\omega^2 R$ and this is positive at the bottom and minus at the top (when the yoke is about to change direction)

Since $R \sin(\omega t) = x$ then substituting x we find $a = -\omega^2 x$

This is the usual definition of S.H.M. The equation tells us that any body that performs sinusoidal motion must have an acceleration that is directly proportional to the displacement and is always directed to the point of zero displacement. The constant of proportionality is ω^2 . Any vibrating body that has a motion that can be described in this way must vibrate with S.H.M. and have the same equations for displacement, velocity and acceleration.

1.4 ANGULAR FREQUENCY, FREQUENCY AND PERIODIC TIME

ω is the angular velocity of the wheel but in any vibration such as the mass on the spring, it is called the angular frequency as no physical wheel exists.

The frequency of the wheel in revolutions/second is equivalent to the frequency of the vibration. If the wheel rotates at 2 rev/s the time of one revolution is 1/2 seconds. If the wheel rotates at 5 rev/s the time of one revolution is 1/5 second. If it rotates at f rev/s the time of one revolution is $1/f$. This formula is important and gives the periodic time.

Periodic Time T = time needed to perform one cycle.

f is the frequency or number of cycles per second.

It follows that **$T = 1/f$ and $f = 1/T$**

Each cycle of an oscillation is equivalent to one rotation of the wheel and 1 revolution is an angle of 2π radians. When $\theta = 2\pi$, $t = T$.

It follows that since $\theta = \omega t$ then $2\pi = \omega T$

Rearrange and $\omega = 2\pi/T$. Substitute $T = 1/f$ and **$\omega = 2\pi f$**

1.5 EQUATIONS OF S.H.M.

Consider the three equations derived earlier.

Displacement	$x = R \sin(\omega t).$
Velocity	$v = dx/dt = \omega R \cos(\omega t)$
Acceleration	$a = dv/dt = -\omega^2 R \sin(\omega t)$

The plots of x , v and a against angle θ are shown on figure 7a. In the analysis so far made, we measured angle θ from the horizontal position and arbitrarily decided that the time was zero at this point. Suppose we start the timing after the angle has reached a value of ϕ from this point. In these cases, ϕ is called the phase angle. The resulting equations for displacement, velocity and acceleration are then as follows.

Displacement	$x = R \sin(\omega t + \phi).$
Velocity	$v = dx/dt = \omega R \cos(\omega t + \phi)$
Acceleration	$a = dv/dt = -\omega^2 R \sin(\omega t + \phi)$

The plots of x , v and a are the same but the vertical axis is displaced by ϕ as shown on figure 7b. A point to note on figure 7a and 7b is that the velocity graph is shifted $\frac{1}{4}$ cycle (90°) to the left and the acceleration graph is shifted a further $\frac{1}{4}$ cycle making it $\frac{1}{2}$ cycle out of phase with x .

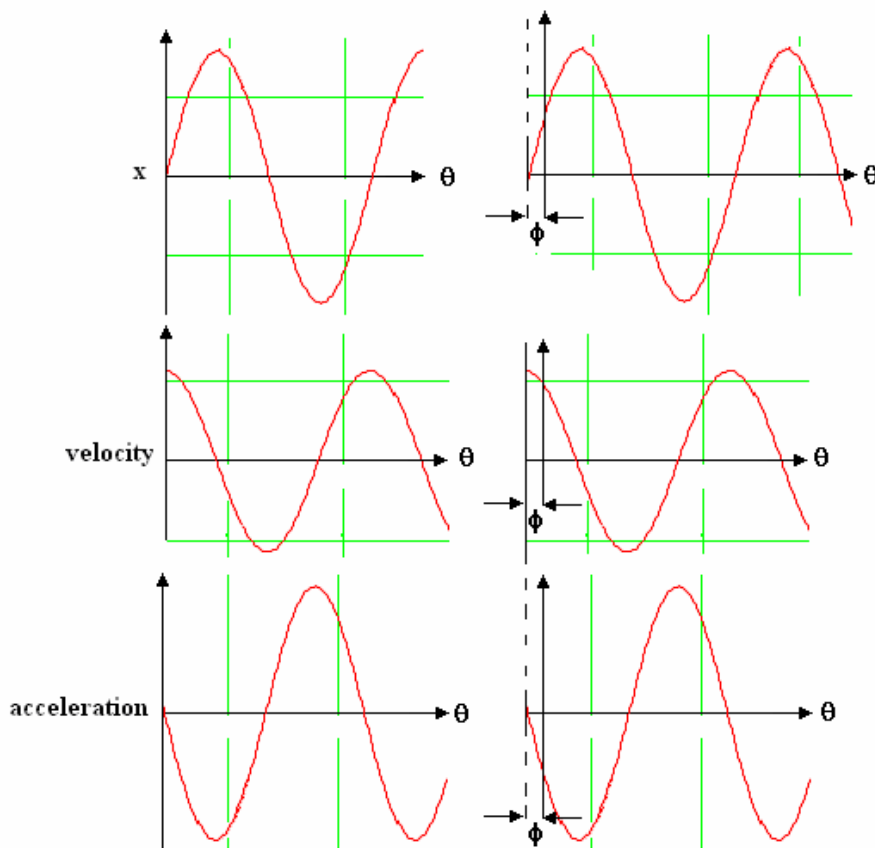

Figure 7a

Figure 7b

WORKED EXAMPLE No.1

The displacement of a body performing simple harmonic motion is described by the following equation

$x = A \sin(\omega t + \phi)$ where A is the amplitude, ω is the natural frequency and ϕ is the phase angle. Given $A = 20 \text{ mm}$, $\omega = 50 \text{ rad/s}$ and $\phi = \pi/8$ radian, calculate the following.

- i. The frequency.
- ii. The periodic time.
- iii. The displacement, velocity and acceleration when $t = T/4$.

Sketch the graphs of x , v and a and confirm your answers.

SOLUTION

First deduce the frequency. $f = \omega/2\pi = 50/2\pi = 7.96 \text{ Hz}$.

Next deduce the periodic time. $T = 1/f = 0.126 \text{ s}$

Next deduce the time t . $t = T/4 = 0.0314 \text{ s}$

Next write out the equation for displacement and solve x at $t = 0.0314 \text{ s}$

$$x = 20 \sin\left(50 \times 0.0314 + \frac{\pi}{8}\right)$$

$$x = 20 \sin\left(1.57 + \frac{\pi}{8}\right) = 20 \sin 1.963 = 18.48 \text{ mm}$$

Next write down the equations for v and a

$$x = 20 \sin(\omega t + \phi)$$

$$v = 20\omega \cos(\omega t + \phi) = 20 \times 50 \times \cos(1.963) = -382.2 \text{ mm/s}$$

$$a = -20\omega^2 \sin(\omega t + \phi) = -20 \times 50^2 \sin(1.963) = -46203 \text{ mm/s}^2$$

The plots of x , v and a confirm these answers.

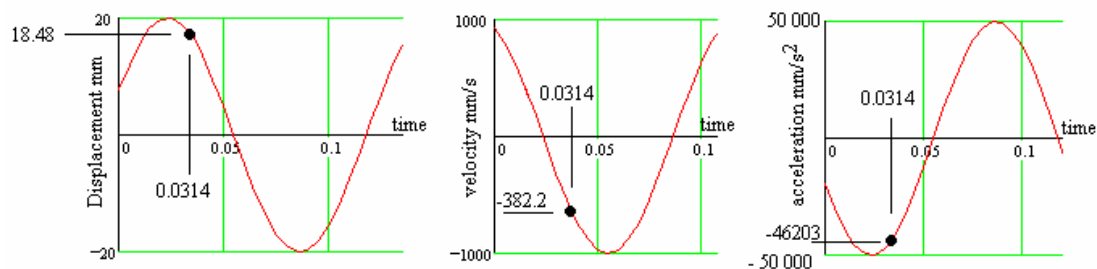

Figure 8

2. NATURAL VIBRATIONS - EXPLANATION

In the following work we will show how some simple cases of natural vibrations are examples of simple harmonic motion. Remember that one important point common to all of them is that there must be a natural force that makes the body move to the rest position. Another point common to all the following examples is that the body has mass (inertia) and that in order to accelerate, there must be an inertia force or torque present.

A free vibration has no external energy added after it starts moving so it follows that all the forces and all the moment of force acting on the body must add up to zero. This is the basis of the analysis.

3 SIMPLE PENDULUM

The restoring force in this case is gravity. When the pendulum is displaced through an angle θ , the weight tries to restore it to the rest position. This analysis is based on moment of force (torque).

RESTORING TORQUE Weight = mg

To find any moment we must always use the distance to the centre of rotation measured at 90° (normal) to the direction of the force. In this case the distance is $L \sin\theta$

Denote the torque as T_g . This tries to return the mass to the rest position.

$$T_g = \text{weight} \times mg (L \sin\theta)$$

INERTIA TORQUE

Since the pendulum has angular acceleration α as it slows down and speeds up, it requires an inertia torque to produce it. Denote this torque as T_i .

From Newton's second law for angular motion $T_i = I\alpha$

α is the angular acceleration and I is the moment of inertia.

The mass is assumed to be concentrated at radius L . (If it was not, the problem would be more complicated). The moment of inertia is then simply given as $I = mL^2$

BALANCE OF MOMENTS

If there is no applied torque from any external source, then the total torque on the body must be zero.

$$\begin{aligned} T_g + T_i &= 0 \\ mg L \sin\theta + mL^2\alpha &= 0 \\ mg L \sin\theta &= - mL^2\alpha \\ g L \sin\theta &= -L^2\alpha \end{aligned}$$

The sin of small angles is very similar to the angle itself in radians (try it on your calculator). The smaller the angle, the truer this becomes. In such cases $\sin(\theta) = \theta$ radians and so we may simplify the equation to

$$\begin{aligned} g\theta &= -L\alpha \\ \alpha &= -(g/L)\theta \end{aligned}$$

This meets the requirements for SHM since the acceleration α is directly proportional to the displacement θ and the minus sign indicates that it is always accelerating towards the rest point. It follows that the constant of proportionality is so (g/L) .

$$\omega^2 = g/L \quad \omega = (g/L)^{1/2}$$

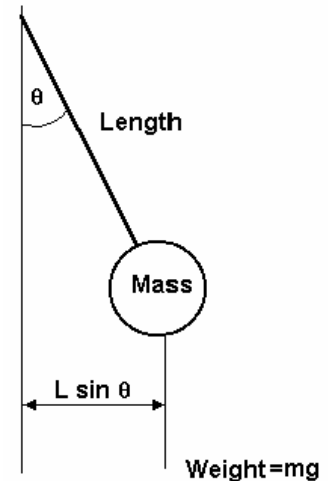

Figure 9

If the displacement θ was plotted against time the same graphs as shown in figure 7 would result. Note that the displacement in this example is angle and should not be confused with the angle on the Scotch Yoke. The frequency of oscillation is obtained from $f = \omega/2\pi$.

Hence
$$f = \frac{1}{2\pi} \sqrt{\frac{g}{L}}$$

Note that the mass makes no difference to the frequency. On earth we can only change the frequency by altering the length L . If we took the pendulum to the moon, it would oscillate more slowly since gravity is smaller. In outer space where g is very close to zero, the pendulum would have no weight and would not swing at all if moved to the side.

Remember also that the above equation is only true if the pendulum swings through a small angle. If the angle is large, the motion is not perfect S.H.M.

WORKED EXAMPLE No.2

A mass is suspended from a string 60 mm long. It is nudged so that it makes a small swinging oscillation. Determine the frequency and periodic time.

SOLUTION

$$f = (1/2\pi) (g/L)^{1/2}$$

$$f = (1/2\pi) (9.81/0.06)^{1/2} = 2.035 \text{ Hz}$$

$$T = 1/f = 0.491 \text{ s}$$

4 LINEAR ELASTIC OSCILLATIONS

Most natural oscillations occur because the restoring force is due to a spring. A spring is any elastic body which when stretched, compressed, bent or twisted, will produce a force or torque directly proportional to displacement. Examples range from the oscillation of a mass on the end of a spring to the motion of a tree swaying in the wind. Let's start with a simple mass suspended on a spring.

4.1 MASS ON SPRING

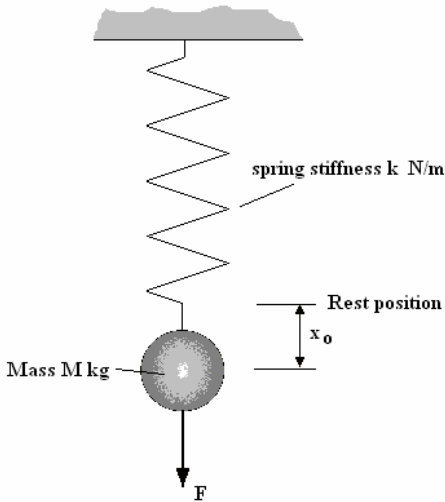

Consider the mass is pulled down with a force F as shown.

The spring is stretched a distance x_0 . This is called the initial displacement.

When the mass is released, it oscillates up and down with simple harmonic motion. Let's analyse the forces involved.

F is the applied force in Newtons.

x is the displacement from the rest position at any time and k is the spring stiffness.

Figure 10

F_s = Spring force that tries to return the mass to the rest position.

From spring theory we know that $F_s = k x$

Since the motion of the mass clearly has acceleration then there is an inertia force F_i .

From Newton's second law of motion we know that $F_i = \text{mass} \times \text{acceleration} = M a$

Balancing forces gives $F = F_i + F_s = M a + k x$

If the mass is disturbed and released so that it is oscillating, the applied force must be zero and this is the requirement for it to be a free natural oscillation.

$$0 = M a + k x \quad \text{Rearrange to make a the subject}$$

$$a = -(k/m) x$$

This is the equation for SHM and tells us the acceleration is directly proportional to displacement and it is directed towards the rest position. If x was plotted against time, a sinusoidal graph would

result. The constant of proportionality is $\frac{k}{M}$ and this must be the angular frequency squared so

$$\omega = \sqrt{\frac{k}{M}}$$

The frequency of oscillation is $f = \frac{\omega}{2\pi} = \frac{1}{2\pi} \sqrt{\frac{k}{M}}$

Because this is a natural oscillation the frequencies are often denoted as ω_n and f_n . This equation is true for all elastic oscillations.

WORKED EXAMPLE No.3

A spring of stiffness 20 kN/m supports a mass of 4 kg. The mass is pulled down 8 mm and released to produce linear oscillations. Calculate the frequency and periodic time. Sketch the graphs of displacement, velocity and acceleration. Calculate the displacement, velocity and acceleration 0.05 s after being released.

SOLUTION

$$\omega = \sqrt{\frac{k}{M}} = \sqrt{\frac{20000}{4}} = 70.71 \text{ rad/s}$$

$$f = \frac{\omega}{2\pi} = 11.25 \text{ Hz}$$

$$T = \frac{1}{f} = 0.0899 \text{ s}$$

The oscillation starts at the bottom of the cycle so $x_0 = -8 \text{ mm}$. The resulting graph of x against time will be a negative cosine curve with an amplitude of 8 mm.

The equations describing the motion are as follows.

$$x = x_0 \cos \omega t$$

$$\text{When } t = 0.05 \text{ seconds } x = -8 \cos(70.71 \times 0.05)$$

$$x = 7.387 \text{ mm. (Note angles are in radian)}$$

This is confirmed by the graph.

If we differentiate once we get the equation for velocity.

$$v = -\omega x_0 \sin \omega t$$

$$v = -\omega x_0 \sin \omega t = -70.71 (-8) \sin(70.71 \times 0.05)$$

$$v = -217 \text{ mm/s}$$

This is confirmed by the graph.

Differentiate again to get the acceleration.

$$a = -\omega^2 x_0 \cos \omega t \text{ and since } x = x_0 \cos \omega t \text{ } a = -\omega^2 x$$

$$a = -70.71^2 \times 7.387 = -36934 \text{ mm/s}^2$$

This is confirmed by the graph.

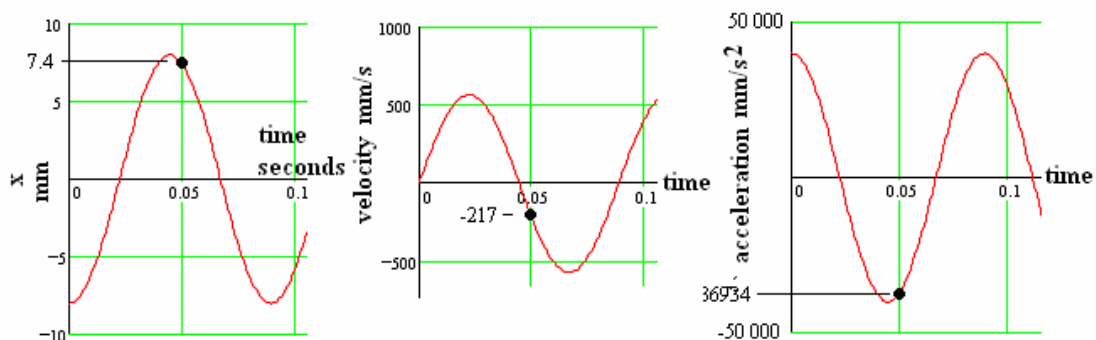

Figure 11

SELF ASSESSMENT EXERCISE No.1

1. Calculate the frequency and periodic time for the oscillation produced by a mass – spring system given that the mass is 0.5 kg and the spring stiffness is 3 N/mm. (12.3 Hz, 0.081 s).
2. A mass of 4 kg is suspended from a spring and oscillates up and down at 2 Hz. Determine the stiffness of the spring. (631.6 N/m).

The amplitude of the oscillation is 5 mm. Determine the displacement, velocity and acceleration 0.02 s after the mass passes through the mean or rest position in an upwards direction. (1.243 mm, 60.86 mm/s and -196.4 mm/s²)

3. From recordings made of a simple harmonic motion, it is found that at a certain point in the motion the velocity is 0.3 m/s and the displacement is 20 mm, both being positive downwards in direction. Determine the amplitude of the motion and the maximum velocity and acceleration. Write down the equations of motion.

Note that the data given is at time $t = 0$. You will have to assume that

$$x = x_0 \cos(\omega t + \phi) \text{ at time } t=0$$

Ans. $x = 0.0311 \cos(\omega t - 50^\circ)$
 $v = -0.3914 \sin(\omega t - 50^\circ)$
 $a = -157.9 x$

4.2 TRANSVERSE VIBRATIONS

A transverse oscillation is one in which the motion is sideways to the length. This occurs in shafts and beams. They may be solved as either angular or linear motion and linear is chosen here.

CANTILEVER

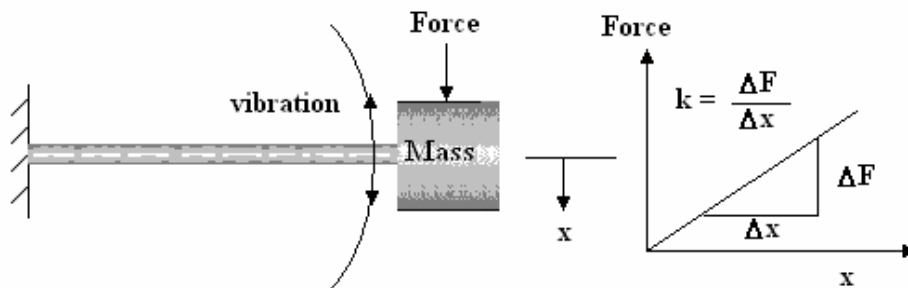

Figure 12

Consider a mass on the end of a cantilever beam. If the mass is moved sideways to the beam, the beam bends and it will always be found that the force is directly proportional to displacement. In other words, it is simple transverse spring. The stiffness of the beam may be found from beam theory. For example in the tutorial on beams it was shown that the deflection of a cantilever due to the point load on the end is given by

$$y = \frac{FL^3}{3EI}$$

y is the symbol for the deflection of a beam but since we have denoted the displacement as x in the

studies so far so we will use $x = \frac{FL^3}{3EI}$

The stiffness is hence $k = \frac{F}{x} = \frac{3EI}{L^3}$

The theory is the same as a mass on the spring so $f = \frac{1}{2\pi} \sqrt{\frac{k}{M}} = \frac{1}{2\pi} \sqrt{\frac{3EI}{ML^3}}$

SIMPLY SUPPORTED BEAM

For a simply supported beam with a point load at the middle, the deflection is $x = \frac{FL^3}{48EI}$ and it

follows that $k = \frac{48EI}{L^3}$ and $f = \frac{1}{2\pi} \sqrt{\frac{48EI}{ML^3}}$

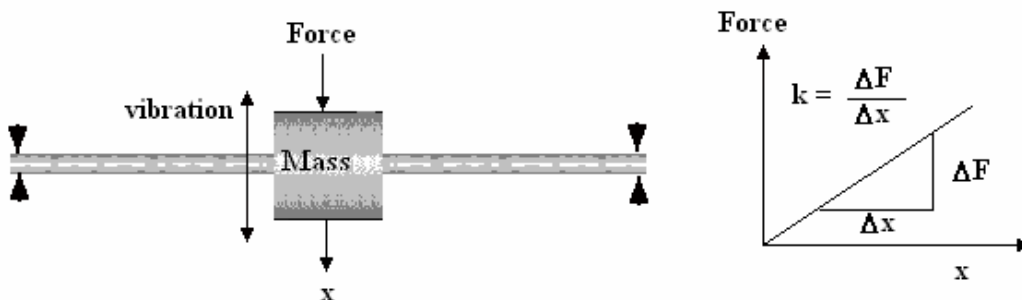

Figure 13

STATIC DEFLECTION

The stiffness may also be found by measuring the static deflection. Suppose the mass deflects a distance x_s under its own weight. The force is the weight so $F = Mg$.

It follows that

$$k = \frac{Mg}{x_s}$$
$$f = \frac{1}{2\pi} \sqrt{\frac{k}{M}} = \frac{1}{2\pi} \sqrt{\frac{g}{x_s}}$$

This formula works for both a cantilever and a simply supported beam. Note that none of the forgoing work takes into account the mass of the beam or shaft and unless this is small in comparison to the concentrated mass, the formulae does not give accurate answers. This is covered later.

WORKED EXAMPLE No.4

A rod 20 mm diameter and 1.2 m long is rigidly fixed at one end and has a mass of 2 kg concentrated at the other end. Ignoring the weight of the rod, calculate the frequency of transverse vibrations. Take $E = 200$ GPa.

SOLUTION

First calculate the second moment of area. For a circular section :

$$I = \frac{\pi D^4}{64} = \frac{\pi \times 0.02^4}{64} = 7.854 \times 10^{-9} \text{ m}^4$$
$$f = \frac{1}{2\pi} \sqrt{\frac{3EI}{ML^3}} = \frac{1}{2\pi} \sqrt{\frac{3 \times 200 \times 10^9 \times 7.854 \times 10^{-9}}{2 \times 1.2^3}} = 5.88 \text{ Hz}$$

WORKED EXAMPLE No.5

A horizontal shaft may be treated as a simply supported beam and has a mass of 40 kg placed at the middle and it deflects 1 mm under the weight. Ignore the mass of the shaft and calculate the frequency of transverse oscillations.

SOLUTION

$$f = \frac{1}{2\pi} \sqrt{\frac{g}{x_s}} = \frac{1}{2\pi} \sqrt{\frac{9.81}{0.001}} = 15.76 \text{ Hz}$$

SELF ASSESSMENT EXERCISE No.2

1. A shaft is mounted horizontally between two bearings. A mass is hung from the centre point and the shaft deflects 2 mm. Calculate the natural frequency of the shaft due to this weight only.
(11.145 Hz)
2. A beam is 4 m long and rests on simple supports at each end. The beam has a second moment of area I of $800 \times 10^{-9} \text{ m}^4$ and a modulus of elasticity of 180 GPa. It has a mass of 30 kg placed at the middle. Calculate the natural frequency of the shaft due to this weight only.
(9.549 Hz)

4.3. ENERGY METHODS (RAYLEIGH)

Rayleigh came up with a method of solving complex oscillations for mass – spring systems based on the fact during an oscillation the maximum kinetic energy of the oscillating mass is equal to the maximum strain (spring) energy. This may be illustrated at a basic level by considering a simple mass on a spring.

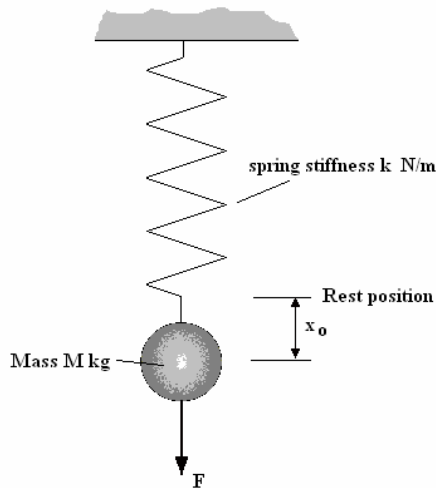

Figure 14

Let the maximum deflection of the mass be x_0 . The spring force is $F = k x_0$. The work done is $\frac{1}{2} F x_0 = \frac{1}{2} k x_0^2$

Let the displacement at any time be

$$x = x_0 \sin \omega t$$

The velocity is

$$v = \omega x_0 \cos \omega t$$

The maximum value is ωx_0

The maximum kinetic energy = $\frac{1}{2} M v^2$

$$\text{K.E. (max)} = \frac{1}{2} M \omega^2 x_0^2$$

Equate energy and $\frac{1}{2} k x_0^2 = \frac{1}{2} M \omega^2 x_0^2$

$\omega^2 = k/M$ and this is the same result found earlier.

An important point to note is that the result would be the same whatever value is chosen for displacement. The deflection due to the static mass could be used and this would lead to the same result so it is arguable that the forgoing including the static deflection method, is a result of applying Rayleigh's method. The method is particularly useful for transverse oscillations.

WORKED EXAMPLE No.6

Calculate the natural frequency of the system shown ignoring the mass of the shaft. The flexural stiffness is $EI = 20\,300 \text{ N m}^2$.

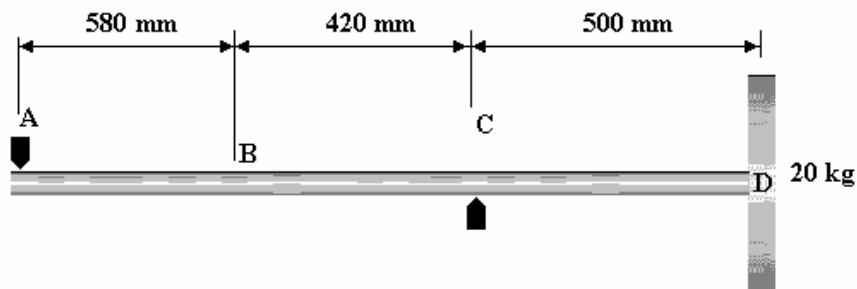

Figure 15

SOLUTION

We can use two different but related strategies. We could determine the strain energy or the static deflection. Let's use the strain energy method. First determine the reactions at A and C.

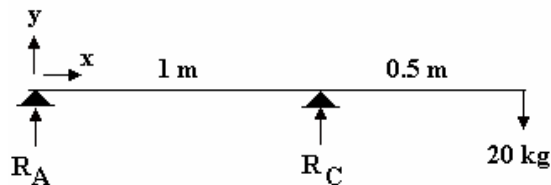

Figure 16

Moments about the left end yields $20 \times 1.5 = R_C \times 1$ $R_C = 30 \text{ kg}$ and hence $R_A = 10 \text{ kg}$ down.
 $R_A = -98.1 \text{ N}$ $R_B = 294.3 \text{ N}$ Up and the load on the end is 196.2 N down.

STRAIN ENERGY FOR SECTION A to C

$$U = \frac{1}{2EI} \int M^2 dx = \frac{1}{2 \times 20300} \int_0^1 (-98.1x)^2 dx = \frac{98.1^2}{2 \times 20300} \left[\frac{x^3}{3} \right]_0^1 = 0.079 \text{ Joules}$$

STRAIN ENERGY FOR SECTION C to B

This is simplified if we measure x from the free end and then $M = -196.2x$

$$U = \frac{1}{2EI} \int M^2 dx = \frac{1}{2 \times 20300} \int_0^{0.51} (-196.2x)^2 dx = \frac{196.2^2}{2 \times 20300} \left[\frac{x^3}{3} \right]_0^{0.51} = 0.0395 \text{ Joules}$$

The total strain energy is $U = 0.0395 + 0.079 = 0.1185 \text{ J}$

The deflection produced at the free end is y_m

The strain energy = $\frac{1}{2} F y_m$ and $F = \text{weight} = 20g = 196.2 \text{ N}$

Hence $y_m = 2 \times 0.1185 / 196.2 = 0.0012 \text{ m}$ or 1.2 mm

If a mass is oscillating up and down sinusoidally $y = y_m \sin \omega t$

The velocity is $\omega y_m \cos(\omega t)$

The kinetic energy is $\frac{1}{2} Mv^2/2 = \frac{1}{2} M\{\omega y_m \cos(\omega t)\}^2$

Maximum value of $\frac{1}{2} M/2\{\omega y_m\}^2$

y_m is the deflection at the end = 0.0021 m $M = 20$ kg

Equating energies we have $\frac{1}{2} M\{\omega y_m\}^2 = 0.1185$

$$10 \omega^2 (0.0021^2) = 0.1185$$

$$\omega^2 = 0.1185/\{10 (0.0021^2)\} = 8229 \quad \omega = 90.7 \text{ rad/s} \quad f = 90.7/(2\pi) = 14.43 \text{ Hz}$$

Note we could have found the static deflection by beam theory and then used

$$f_n = (1/2\pi)\sqrt{(g/y_m)} = (1/2\pi)\sqrt{(g/0.0012)} = 14.4 \text{ Hz}$$

Also note that if the disc on the shaft is large, the disc will rotate about its diameter as the shaft deflects and so angular kinetic energy will also be involved.

4.4 TRANSVERSE VIBRATIONS DUE TO THE DISTRIBUTED MASS

Beams and shafts of many possible configurations (cantilever, simply supported, encastré and so on) will vibrate in much the same manner as the string on a musical instrument. Each configuration will produce a natural frequency depending on the mass, how it is distributed and the transverse spring stiffness. These oscillations can be approached by consideration of the energy changes involved. When a beam is bent, longitudinal layers become stretched and compressed so that strain energy is stored in it. When the beam oscillates it has a velocity at any moment in time and hence has kinetic energy. The strain energy and kinetic energy are converted back and forth from one to the other. The energy trapped in the system cannot get out and cannot stay static so this interchange of energy occurs with the total energy being conserved (assuming no damping).

STRAIN ENERGY

Consider a simply supported beam with negligible mass. Suppose a weight hanger is suspended from it at distance x metres from the end. Further suppose that weights are added to the hanger in small increments causing the beam to deflect a distance y .

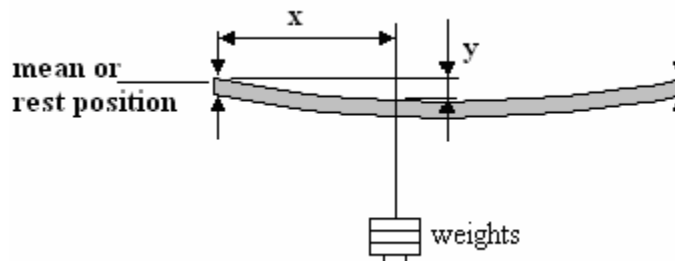

Figure 17

If we conducted this experiment and plotted the weights W Newtons against deflection y we would get a straight line graphs as shown. The maximum weight is W and the maximum deflection is y_m .

The work done is the area under the graph (a triangle). **Work Done** = $\frac{1}{2} W y_m$

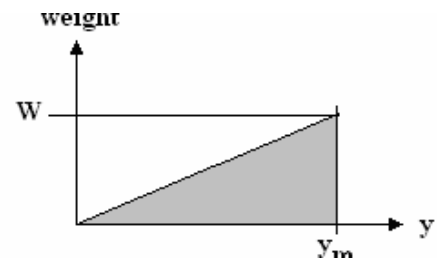

Figure 18

Since an equal amount of energy has been used to deflect the beam, this energy must be stored in the beam as mechanical energy due to the stretching and compression of the material along the length. This is strain energy and we normally denote it as U . The strain energy stored in the beam is hence $U = \frac{1}{2} W y_m$

Now consider a beam that does not have a negligible mass and is uniform along its length with a distributed weight of w N/m. Consider a small length of the beam δx at distance x metres from the left end.

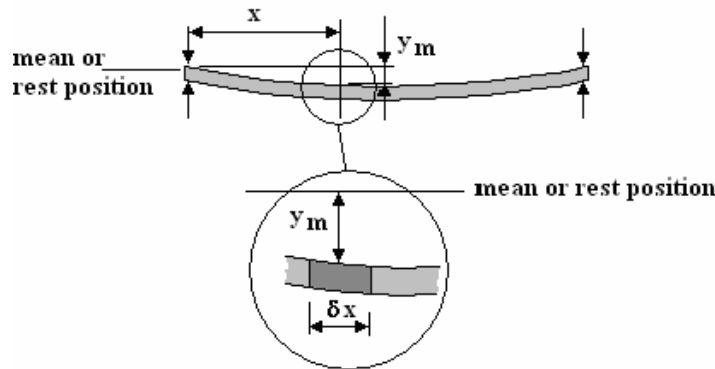

Figure 19

The weight of the element is $w \delta x$ Newtons. This is equivalent to the weight W in figure 17 so the strain energy is a small part of the total $\delta U = \frac{1}{2} w \delta x y_m$.

The strain energy is due to the weight of the small length only so if we want the strain energy for the whole length of the beam we must integrate along the length. Reverting to calculus $\delta x \rightarrow dx$ and $\delta U \rightarrow dU$ then

$$U = \frac{w}{2} \int y_m dx$$

KINETIC ENERGY

If at any moment in time the velocity of the element is v then the kinetic energy of the element is $\frac{1}{2} \delta m v^2$ where δm is the small part of the total mass. The mass of the element is

$$\delta m = w \frac{\delta x}{g}$$

In order to understand the velocity of the element we need to consider the S.H.M., which it performs. y_m is the amplitude of the motion. The deflection is zero at horizontal point so we can describe the displacement (y) with the following equation.

The deflection at any moment is $y = y_m \sin \omega t$

The velocity is $v = dy/dt = \omega y_m \cos \omega t$

The maximum velocity is hence ωy_m .

The time plots of y and v are as shown.

The kinetic energy of the small element at any time is then

$$\delta(\text{K.E.}) = \frac{1}{2} \frac{w \delta x}{g} (\omega y_m \cos \omega t)^2$$

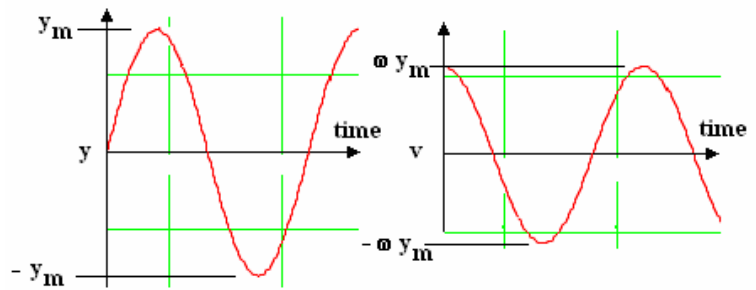

Figure 20

The maximum value is when the cosine has a value of 1. The maximum K.E. of the element is

$$\delta(\text{K.E.})(\text{max}) = \frac{1}{2} \frac{w}{g} \omega^2 y_m^2 \delta x$$

The maximum K.E. for the whole beam is found by integrating with respect to x . Again revert to calculus $\delta x \rightarrow dx$ and $\delta(\text{K.E.}) \rightarrow d(\text{K.E.})$ then

$$\text{K.E.}(\text{max}) = \frac{w \omega^2}{2g} \int y_m^2 dx$$

Equating U and K.E. we have
$$\frac{w}{2} \int y_m dx = \frac{w \omega^2}{2g} \int y_m^2 dx$$

From this the angular frequency of the vibration is
$$\omega^2 = \frac{g \int y_m dx}{\int y_m^2 dx} \text{ and } f = \frac{\omega}{2\pi}$$

In order to evaluate this expression, the function relating the deflection y_m and position x must be known. In the case of a simply supported beam we know this is as follows.

SIMPLY SUPPORTED BEAM

$$y_m = \frac{w}{24EI} [2Lx^3 - x^4 - L^3x]$$
 and the solution (which is hard to do) is

$$f = \frac{\pi}{2} n^2 \sqrt{\frac{gEI}{wL^4}}$$
 where n is the mode and must be an integer 1, 2, 3

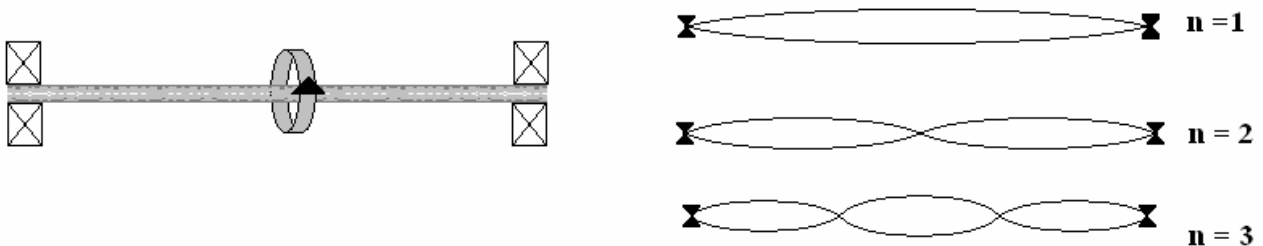

Figure 21

FIXED ENDS (Encastre Beam)

The lowest critical speed is $f = 3.562 \sqrt{\frac{gEI}{wL^4}}$ and the higher critical speeds are given by

$$f = \frac{\pi}{2} \left(n + \frac{1}{2} \right)^2 \sqrt{\frac{gEI}{wL^4}}$$
 where $n = 2, 3, \dots$. Note that the lowest speed almost corresponds to $n = 1$

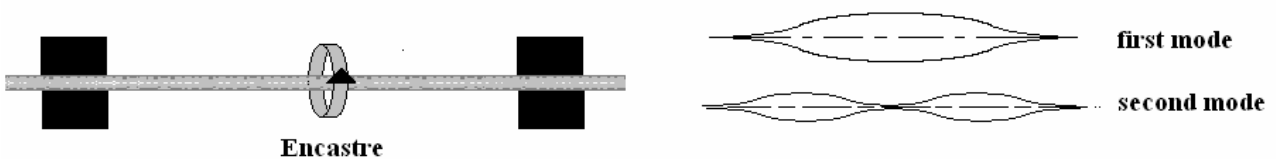

Figure 22

CANTILEVER

The lowest critical speed is $f = 0.565 \sqrt{\frac{gEI}{wL^4}}$

$f = \frac{\pi}{2} \left(n - \frac{1}{2} \right)^2 \sqrt{\frac{gEI}{wL^4}}$ where $n = 2, 3, \dots$. Note that the lowest speed almost corresponds to $n = 1$

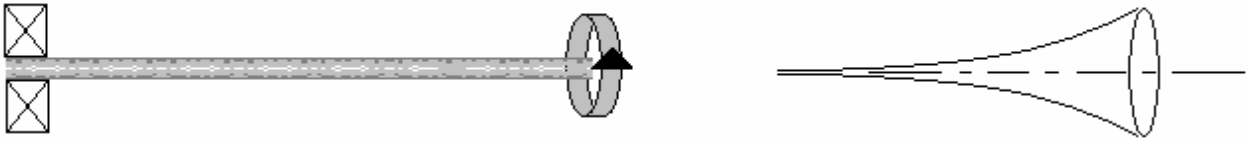

Figure 23

4.5 COMBINATION OF DISTRIBUTED AND POINT LOADS.

When a beam or shaft has one or more concentrated masses as well as a uniformly distributed mass, the frequency of oscillation may be found using Dunkerley's method.

DUNKERLEY'S METHOD

This is a method, which enables the frequency of an oscillation to be deduced when it is due to two or more masses. For example a cantilever oscillates because of its distributed mass and because of any point loads on it. We know how to work these out separately.

Suppose a beam oscillates a frequency f_1 due to one load on its own, f_2 due to another load on its own and f_3 due to a third load on its own. When all three loads vibrate together, the resulting frequency f is found using the reciprocal rule below.

$$\frac{1}{f^2} = \frac{1}{f_1^2} + \frac{1}{f_2^2} + \frac{1}{f_3^2} \quad \text{This formula is based on observation and works very well.}$$

WORKED EXAMPLE No.7

A cantilever beam is 2 m long and has a cross section 60 mm wide and 40 mm deep. It is made from a material with a density of 2800 kg/m³ and a modulus of elasticity of 78 GPa. It has a mass of 5 kg attached on the end. Calculate the following.

- The natural frequency due to its own weight only.
- The natural frequency due to the point load only.
- The combined frequency.

SOLUTION

The natural frequency due to its own weight is

$$f = 0.56 \sqrt{\frac{gEI}{wL^4}}$$

First calculate the weight of 1 metre length (w).

$$\text{Volume} = \text{sectional area} \times \text{length} = 0.06 \times 0.04 \times 1 = 0.0024 \text{ m}^3$$

$$\text{Next change this to mass. } m = \text{density} \times \text{volume} = 2800 \times 0.0024 = 6.72 \text{ kg/m.}$$

$$\text{Next change this to weight. } w = mg = 6.72 \times 9.81 = 65.92 \text{ N/m}$$

Next calculate the second moment of area about the horizontal centre line.

$$I = \frac{BD^3}{12} = \frac{0.06 \times 0.04^3}{12} = 320 \times 10^9 \text{ m}^4$$

Now calculate f

$$f = 0.56 \sqrt{\frac{gEI}{wL^4}} = 0.56 \sqrt{\frac{9.81 \times 78 \times 10^9 \times 320 \times 10^{-9}}{65.92 \times 2^4}} = 8.532 \text{ Hz}$$

The natural frequency due to the mass at the end only is $f = \frac{1}{2\pi} \sqrt{\frac{48EI}{ML^3}}$

Evaluate this.

$$f = \frac{1}{2\pi} \sqrt{\frac{48 \times 78 \times 10^9 \times 320 \times 10^{-9}}{5 \times 2^3}} = 27.5 \text{ Hz}$$

Now find the combined frequency.

$$\frac{1}{f^2} = \frac{1}{f_1^2} + \frac{1}{f_2^2} = \frac{1}{8.532^2} + \frac{1}{27.54^2} = 0.015$$

$$f^2 = 66.42 \quad f = 8.15 \text{ Hz}$$

WORKED EXAMPLE No.8

A light shaft carries a pulley at the centre with its centre of gravity on the centre line. The shaft is supported in self aligning bearing at the ends. The shaft deflects 0.5 mm under the static weight of the shaft. Determine the lowest natural frequency.

SOLUTION

The frequency corresponds to that of a simply supported beam so

$$f = \frac{1}{2\pi} \sqrt{\frac{g}{x_s}} = \frac{1}{2\pi} \sqrt{\frac{9.81}{0.0005}} = 22.3 \text{ Hz}$$

WORKED EXAMPLE No.9

The shaft in the previous example has a distributed weight of 40 N/m and the bearings are 1.2 m apart. The flexural stiffness is 4500 N m².

What is the natural frequency?

SOLUTION

The frequency due to the distributed weight only is

$$f = \frac{\pi}{2} \sqrt{\frac{gEI}{wL^4}} = 1.572 \sqrt{\frac{9.81 \times 4500}{40 \times 1.2^4}} = 36.3$$

The critical speed is N is found from

$$\frac{1}{f^2} = \frac{1}{f_1^2} + \frac{1}{f_2^2} = \frac{1}{22.3^2} + \frac{1}{36.3^2} \quad \text{Hence } f = 19 \text{ Hz}$$

WORKED EXAMPLE No.10

A steel wire 2 mm diameter is held between chucks 1m apart. The wire weighs 0.241 N/m. The flexural stiffness is 0.157 N m². Calculate the first and second mode frequencies.

SOLUTION

The lowest frequency due to the distributed weight only is

$$f = 3.562 \sqrt{\frac{gEI}{wL^4}} = 3.562 \sqrt{\frac{9.81 \times 0.157}{0.241 \times 1^4}} = 9 \text{ Hz}$$

The second mode frequency is $f = \frac{\pi}{2} \left(n + \frac{1}{2} \right)^2 \sqrt{\frac{gEI}{wL^4}} = \frac{\pi}{2} \left(2 + \frac{1}{2} \right)^2 \sqrt{\frac{9.81 \times 0.157}{0.241 \times 1^4}} = 24.8 \text{ Hz}$

SELF ASSESSMENT EXERCISE No.3

- 1a. A shaft is 20 mm diameter and 3 m long and simply supported at each end. The density is 7 830 kg/m³. E = 205 GPa. Calculate the natural frequency. (Ans. 4.47 Hz)
The same shaft has a flywheel mounted at the middle of mass 10 kg
- 1b. Calculate the new natural frequency due to the point load only. (Ans. 2.69 Hz)
- 1c. Calculate the combined natural frequency for the uniform and point load. (Ans. 2.3 Hz)

2. A shaft 1.8 m long and 30 mm diameter has an moment of inertia of 2.5 kg m² at one end and 4 kg m² at the other end. The shaft rests in bearings. The modulus of rigidity is 80 GN/m². Calculate the natural frequency of torsional vibrations and the position of the node.
(Answers 7.628 Hz and 1.108 m from the smaller inertia)

3. A shaft 30 mm diameter is made from steel with density 7830 kg/m³. Calculate the weight per metre (54.3 N/m)

The shaft runs between self aligning bearings 2.2 m apart. The modulus of elasticity E is 200GN/m². Calculate the lowest natural frequency. (12.3 Hz)

A pulley is mounted at the middle and this makes the shaft deflect 1.5 mm. Calculate the lowest natural frequency. (12.7 Hz)

5. A thin rod 5 mm diameter is held between two chucks 0.8 m apart. The wire weighs 1.508 N/m and the flexural stiffness is 6.136 N m². Calculate the first and second mode frequency.
(35.2 Hz and 96.9 Hz)
6. A shaft is 50 mm diameter and 8 m long and may be regarded as simply supported. The density is 7 830 kg/m³. E = 205 GPa. Calculate the first three critical frequencies. (1.571 , 6.279 and 14.13 Hz)
7. An aluminium rod is held in a chuck with the other end unsupported. It is 12 mm diameter and 400 mm long. The density of aluminium is 2710 kg/m³ and the modulus of elasticity E is 71 GPa. Calculate the first two critical frequencies. (54.2 Hz and 340 Hz)

5. TORSIONAL OSCILLATIONS

A torsional oscillation occurs when a restoring torque acts on a body which is displaced by turning it about its axis. The restoring torque may be caused by twisting a shaft or by some other form of spring. A torsional spring produces a torque (T) directly proportional to the angle of twist (θ) such that $T = k_t \theta$.

k_t is the torsional spring constant and for a simple shaft this may be derived in terms of the material dimensions and properties. From the tutorial on torsion we found that:

$$\frac{T}{J} = \frac{G\theta}{L} \text{ from which the torsional spring constant is } k_t = \frac{T}{\theta} = \frac{GJ}{L}$$

Remember that J is the polar second moment of area, L is the length and G is the modulus of rigidity for the material. For a solid round shaft $J = \pi D^4/32$. Consider a flywheel of moment of inertia I on the end of a vertical shaft.

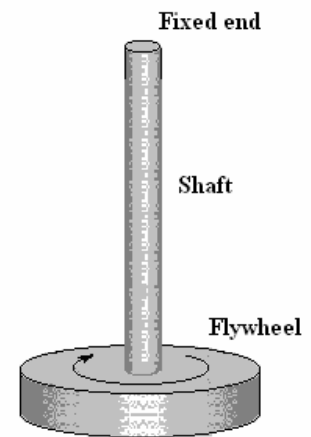

Figure 24

If a torque T is applied to the flywheel it must

- 1) Overcome the inertia (inertia torque) by the law $T = I\alpha$
- 2) Twist the shaft (spring torque) by the law $T = k_t \theta$

Hence $T = I\alpha + K_t \theta$

When the flywheel is released, the torque is zero so $0 = I\alpha + K_t \theta$

Rearrange to make the acceleration (α) the subject $\alpha = -\frac{k_t}{I} \theta$

This shows that the angular acceleration is directly proportional to displacement angle and always towards the rest position so the motion is S.H.M. The constant of proportionality ω^2 hence:

$$\omega^2 = \frac{k_t}{I} \quad f = \frac{\omega}{2\pi} = \frac{1}{2\pi} \sqrt{\frac{k_t}{I}}$$

WORKED EXAMPLE No.11

A vertical shaft 20 mm diameter and 0.8 m long is made from metal with a modulus of rigidity G of 80 GPa. The shaft has a flywheel of moment of inertia 30kg m² mounted on the end. Determine the frequency of the torsional oscillations.

SOLUTION

$$J = \frac{\pi D^4}{32} = \frac{\pi \times 0.02^4}{32} = 15.7 \times 10^{-9} \text{ m}^4$$

$$k_t = \frac{T}{\theta} = \frac{GJ}{L} = \frac{80 \times 10^9 \times 15.7 \times 10^{-9}}{0.8} = 1570.8 \text{ Nm/radian}$$

$$f = \frac{1}{2\pi} \sqrt{\frac{k_t}{I}} = \frac{1}{2\pi} \sqrt{\frac{1570.8}{30}} = 1.152 \text{ Hz}$$

WORKED EXAMPLE No.12

A large drum of radius 0.5 m is mounted on a horizontal surface with a mass of 400 kg on one end. The other end is fixed to a wall. The drum has a moment of inertia of 60 kg m². The belt does not slip on the drum. Also determine the maximum displacement of the mass if the maximum force in the belt is 1000 N.

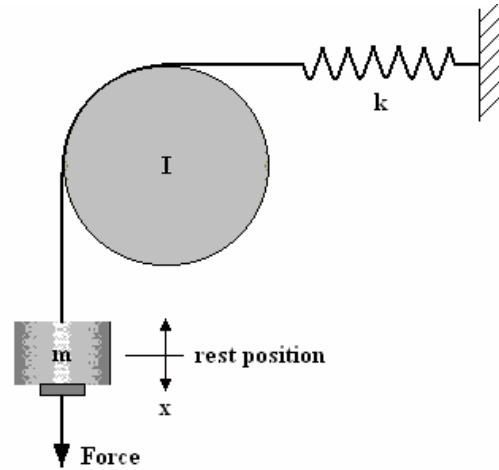

Figure 25

SOLUTION

The solution must be done analytically since it is a combination of torsional and linear oscillations. Suppose the mass is pulled downwards with a force F . This must overcome the inertia of the mass, the inertia of the drum and stretch the spring.

Inertia force to accelerate the drum

The Torque required to overcome the inertia of the drum is $T = I\alpha$

Torque = Force \times radius or $T = F R$ and the force is $F = T/R$

Substitute $T = I\alpha$

$F_{i1} = I\alpha/R$ where α is the angular acceleration of the drum.

Inertia force to accelerate the mass

$F_{i2} = m a$ where a is the linear acceleration.

Force to stretch the spring

$F_s = k x$ where k is the spring stiffness.

Force balance

$$F = F_{i1} + F_{i2} + F_s$$

$$F = I\alpha/R + ma + kx$$

The angular acceleration is linked to the linear acceleration by $\alpha = a/R$ where R is the drum radius.

$$F = Ia/R^2 + ma + kx = a(m + I/r^2) + kx$$

For a free oscillation $F = 0$ hence

$$0 = \frac{Ia}{R^2} + ma + kx = a\left(\frac{I}{R^2} + m\right) + kx \quad \text{Make } a \text{ the subject } a = -\left(\frac{k}{\frac{I}{R^2} + m}\right)x$$

This shows that the acceleration is directly proportional to displacement so the motion must be simple harmonic. The constant of proportionality is the angular frequency squared so:

$$\omega^2 = \left(\frac{k}{\frac{I}{R^2} + m}\right) \quad \omega = \sqrt{\left(\frac{k}{\frac{I}{R^2} + m}\right)} \quad f = \frac{\omega}{2\pi} = \frac{1}{2\pi} \sqrt{\left(\frac{k}{\frac{I}{R^2} + m}\right)}$$

Evaluate f using $k = 300\,000\text{ N/m}$, $m = 400\text{ kg}$, $I = 60\text{ kg m}^2$ and $R = 0.5\text{ m}$

$$f = \frac{1}{2\pi} \sqrt{\frac{300\,000}{\frac{60}{0.5^2} + 400}} = 3.44\text{ Hz}$$

Consider the force in the belt on the side with the spring.

The static force when at rest = weight = $400 \times 9.81 = 3\,924\text{ N}$

When the oscillation changes the length of the spring by 5 mm this is reduced or increased by
 $kx = 300 \times 5 = 1500\text{ N}$

The minimum force is hence $3\,924 - 1500 = 2\,424\text{ N}$

The maximum is $3\,924 + 1500 = 5\,424\text{ N}$

Now consider the side with the mass.

Static force when at rest = $3\,924\text{ N}$

The maximum acceleration occurs when the mass is about to reverse direction and this is when
 $x = 5\text{ mm}$.

From the studies of s.h.m. we know $a = \omega^2 x = 21.65^2 \times 0.005 = 2.34\text{ m/s}^2$

Force in belt to accelerate the mass = $ma = 400 \times 2.34 = 937\text{ N}$

Force in belt when maximum acceleration is upwards is $3\,924 + 937 = 4\,861\text{ N}$

Force in belt when acceleration is downwards is $3\,924 - 937 = 2\,987\text{ N}$

The maximum and minimum forces in the belt are $5\,424\text{ N}$ and $2\,424\text{ N}$ respectively.

SELF ASSESSMENT EXERCISE No.4

1. A large drum of radius 0.12 m is mounted on a horizontal shaft. A belt runs over it as shown in fig.19 with a mass of 10 kg on one end. The other end is restrained with a spring of stiffness 788 N/m .

The drum has a moment of inertia of 0.04 kg m^2 .

Determine the following.

- The natural frequency of the system assuming the belt does not slip on the drum.
- The maximum and minimum forces in the belt on each side given the maximum displacement is 0.1 m .

Ans 1.25 Hz, 160 N and 36.4 N, 176.9 N and 19.3 N.

2. A wheel 0.6 m diameter has a mass of 8 kg and is mounted on a horizontal axle. The wheel is perfectly balanced about the axle. A small mass of 200 g is fixed to the outer edge of the wheel. The wheel is made to oscillate with a small amplitude and the periodic time is found to be 5.9 s . Determine the radius of gyration of the wheel. **(Ans. 0.255 m)**

The maximum amplitude of oscillation is 10° . Find the maximum angular velocity of the wheel as it oscillates. **(Ans. 0.186 rad/s)**

3. A pendulum is shown in fig.20. It consists of a mass of 5 kg on a weightless rod. The centre of gravity G is 400 mm below the pivot. The radius of gyration about G is 0.05 m. Two light springs are attached to the rod at point A as shown each with stiffness 750 N/m. Point A is 120 mm below the pivot.

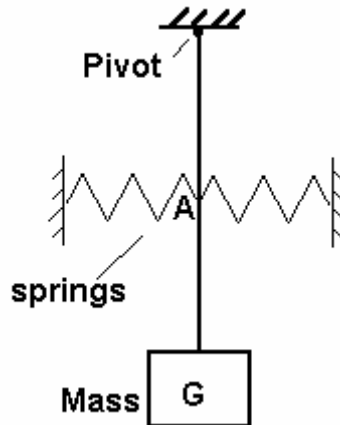

Figure 26

The rod is at rest in the vertical position. Determine the frequency of oscillation if it is disturbed slightly. Note that you need the parallel axis theorem to do this. (Ans 1.13 Hz).

The angular displacement of the rod is 2° when released. Determine the maximum angular acceleration. (Ans. .77 rad/s²)

4. A mass of 4 kg is suspended from a spring and oscillates up and down at 2 Hz. Determine the stiffness of the spring. (Ans. 631.6 N/m).

From recordings made of the oscillation it is found that at a certain point in the motion the velocity is 0.3 m/s and the displacement is 20 mm, both being positive downwards in direction. Determine the amplitude of the motion and the maximum velocity and acceleration. Write down the equations of motion.

Note that the data given is at time $t = 0$. You will have to assume that

$$x = x_0 \cos(\omega t + \phi) \text{ at time } t=0$$

Ans. $x = 0.0311 \cos(\omega t + 50^\circ)$
 $v = 0.3914 \sin(\omega t + 50^\circ)$
 $a = -157.9 x$

6. OSCILLATION OF A FLOATING BODY

You may have observed that some bodies floating in water bob up and down. This is another example of simple harmonic motion and the restoring force in this case is **buoyancy**.

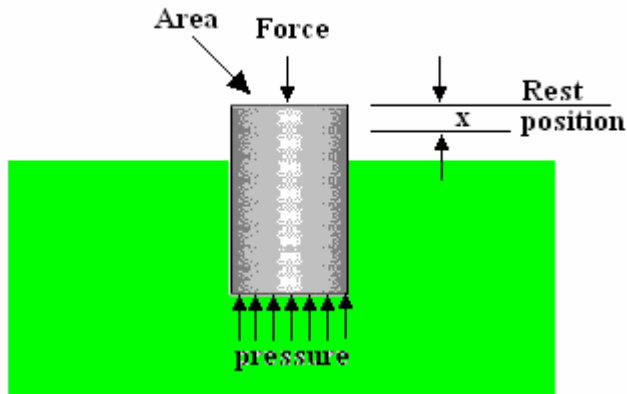

Consider a floating body of mass M kg. Initially it is at rest and all the forces acting on it add up to zero. Suppose a force F is applied to the top to push it down a distance x . The applied force F must overcome this buoyancy force and also overcome the inertia of the body.

Figure 27

BUOYANCY FORCE

The pressure on the bottom increases by $\Delta p = \rho g x$.

The buoyancy force pushing it up on the bottom is F_b and this increases by $\Delta p A$.

Substitute for Δp and $F_b = \rho g x A$

INERTIA FORCE

The inertia force acting on the body is $F_i = M a$

BALANCE OF FORCES

The applied force must be $F = F_i + F_b$ and this must be zero if the vibration is free.

$$0 = F_i + F_b = M a + \rho g x A$$

Make the acceleration the subject.

$$a = -\frac{\rho A g}{M} x$$

This shows that the acceleration is directly proportional to displacement and is always directed towards the rest position so the motion must be simple harmonic and the constant of proportionality must be the angular frequency squared.

$$\omega^2 = \frac{\rho A g}{M}$$

$$\omega = \sqrt{\frac{\rho A g}{M}}$$

$$f = \frac{\omega}{2\pi} = \frac{1}{2\pi} \sqrt{\frac{\rho A g}{M}}$$

SELF ASSESSMENT EXERCISE No.5

1. A cylindrical rod is 80 mm diameter and has a mass of 5 kg. It floats vertically in water of density 1036 kg/m^3 . Calculate the frequency at which it bobs up and down.

(Ans. 0.508 Hz)